



PROTECTA III

LED Linear

The Industrial **Protecta III** is a high quality LED linear delivering unparalleled performance and all the recognised benefits of the existing Protecta range; a proven robust enclosure, excellent IP and low maintenance features which are key to heavy industrial and harsh marine environments.

Expected useful life to 70% of the initial lumens (L70) is a market leading 154,000 hours at 55°C and, combined with a lightweight geartray design utilising fully replaceable LED strips and driver, we can deliver a unique product with effective long term maintenance capabilities.



UK
CA CE

International Approvals

Mounting Options

Ceiling. Wall. Suspended. Pole/Stanchion.

Standard Specification

Protecta III LED Linear

Enclosure	GRP body with polycarbonate cover
Geartray	White coated zintec
Entry	4 x M20 cable entries - 2 at each end
Termination	3 core 4mm ² max conductor with looping and 16A rating through wiring [4 core on Emergency]
Installation	2 x M8 moulded-in stainless steel bushes located on the rear of the body
Control Gear	Electronic Driver
Colour Temperature (CCT)	4000K (Neutral White)
Colour Rendering Index (Ra)	>80
Maintenance	Quick release diffuser clamp and hinged cover
LED Lifetime @ 55°C Ambient	L70 > 154,000hrs
System Life	120,000hrs @ 25°C [excluding battery]
Battery	Internal Ni-Cd (6V) [Emergency version only]
Emergency Duration	3 Hours (02L version = 33% output, 04L version = 23% output, 07L version = 12% output)
Impact Protection	IK10
Ingress Protection	IP66/67 to EN 60529
Surge Protection	02L = 1kV; 04L/07L = 4kV (line to line)
Electrical Supply	120-277V AC, 50/60Hz 127-300V DC [04L/07L]; 127-250V DC [02L] 220-240V AC, 50/60Hz [Emergency version only]

Features

- ◆ Highly **Energy Efficient**
- ◆ **Screwless** mains terminals
- ◆ **DTS-01** deluge tested
- ◆ **Battery monitoring** and **automatic self test**
- ◆ **120,000 maintenance free hours** at 25°C
- ◆ **Simple rugged construction**

Std. Cat No.	Delivered Output	Power Consumption	Ambient °C	Weight
PR31/02L/LE	2296 lm	16W	-40 to +55	4.8kg
PR31/04L/LE	3526 lm	24W	-40 to +55	4.9kg
PR31/07L/LE	6690 lm	44W	-40 to +55	8.2kg
PR31/02L/LE/EM	2296 lm	20W	-25 to +50	5.8kg
PR31/04L/LE/EM	3526 lm	26W	-25 to +50	5.9kg
PR31/07L/LE/EM	6690 lm	49W	-25 to +50	9.2kg

Options - Suffix to Catalogue No.

/M25	M25 cable entries	/5K	5000K (Cool White) LED Strips
/LBE	Looping both sides	/3K	3000K (Warm White) LED Strips
/BP	Nickel plated brass plugs (x3)	/DM	DALI Dimmable driver (04L and 07L only)
/EL	Extra live termination facility (to match emergency circuit)	/NST	Non self test inverter (EM only)
/OD	Internal Opal diffusers (approx. 20% reduction in output)	/SC	Screwed connection terminal block (up to 6mm ² conductors)
/JSVS	Inotec CBS type J-SV Modul/S	/JSVT	Inotec CBS type J-SV Modul T/S

Accessories *Accessories should be ordered separately*

	Order Code
Pole mounting bracket assembly (38-42mm diameter poles)	SPOL4-100001
Pole mounting bracket assembly (48-52mm diameter poles)	SPOL4-100002
Pole mounting bracket assembly (58-62mm diameter poles)	SPOL4-100003
Hook type ceiling bracket assembly	SPRO4-0005
Flush mounted wall bracket assembly	SPRO4-0006
Ceiling bracket assembly	SPRO4-0002
Standard 2ft wall mounting outreach bracket (use with SPOL4-100001)	NPRO4-0008
Standard 4ft wall mounting outreach bracket (use with SPOL4-100001)	NPRO4-0012
Eyebolt mounting assembly	SPRO5-0005
Internal Opal Diffuser Strips (02L & 04L)	S3004-100005
Internal Opal Diffuser Strips (07L)	S3004-100006

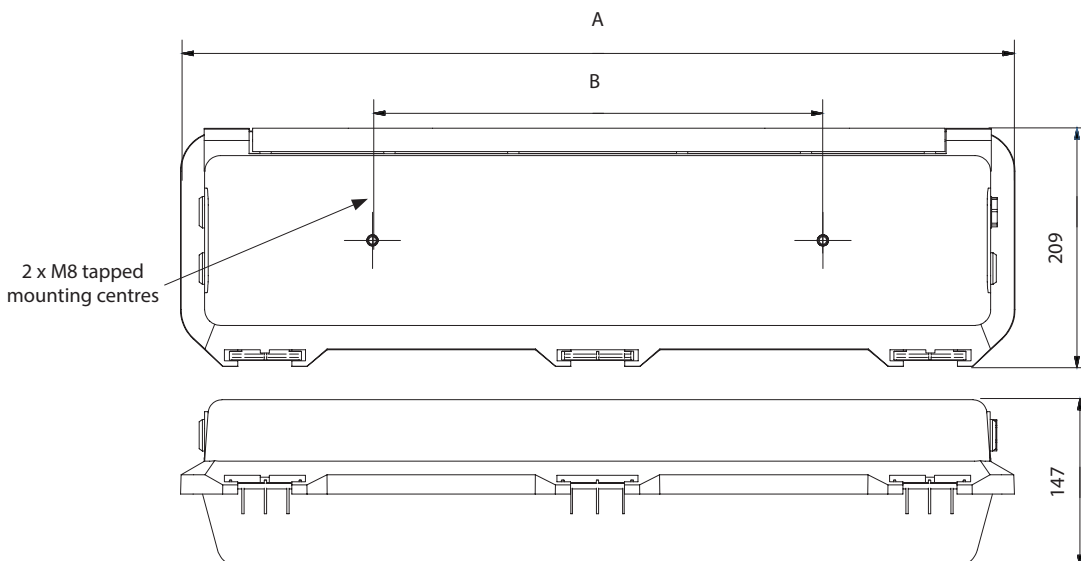

DIM	02L/04L	07L
DIM A	742	1352
DIM B	400	700